

THE NEW VALUE FRONTIER



For Small Parts
Machining

Y-axis Toolholder

For Small Parts Machining

Y-axis Toolholder

NEW



Excellent Chip Evacuation with Y-axis Tuning Prevents Chip Entanglement

New Y-axis Toolholder Design

Available for KTKF Grooving and Cut-Off Systems and External Turning

Advance Your Productivity with Excellent Control of Chip Evacuation

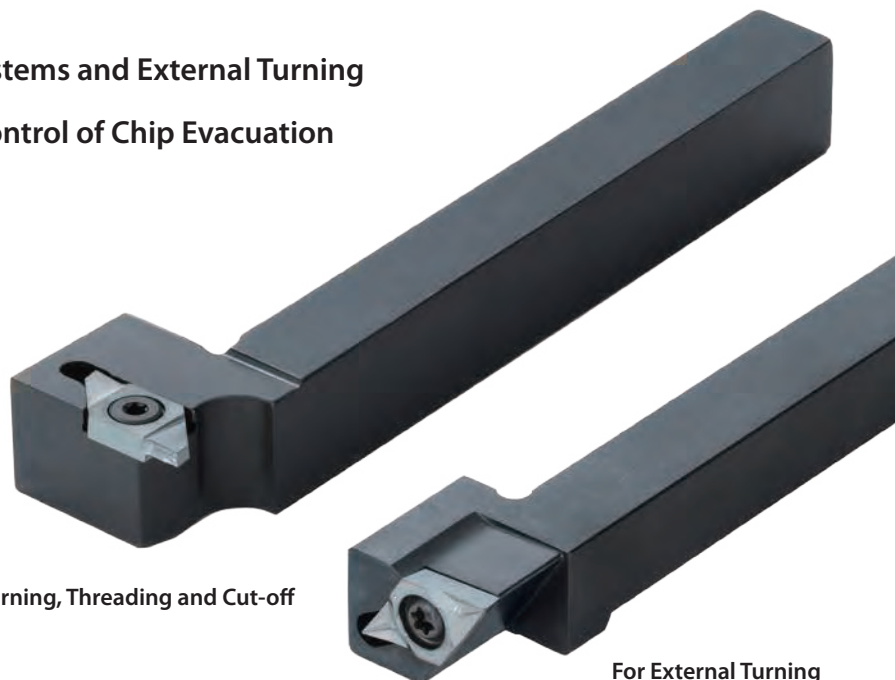

For Back Turning, Threading and Cut-off

For External Turning

Improved Chip Control

Y-axis Toolholder

New Toolholders Designed for Small Parts Machining

1 Controlled Chip Evacuation for Stable Machining

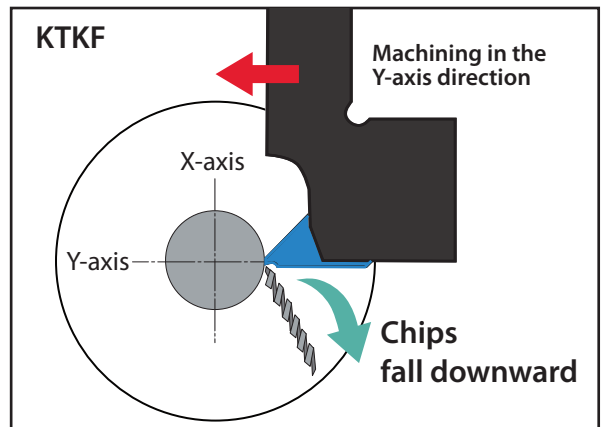

The Y-axis machining direction allows the chips to fall down and away from the workpiece, improving chip evacuation.

2 KTKF Grooving and Cut-Off System and External Turning Holders

KTKF

Back Turning, Threading and Cut-off



KTKFR1216JX-12-Y : Shank 1216 Type
KTKFR1616JX-12-Y : Shank 1616 Type
Applicable inserts: TKF12R...

External Turning

Front turning



SDJCR1212JX-11FF-Y : Shank 1212 Type
SDJCR1616JX-11FF-Y : Shank 1616 Type
Applicable inserts: DC□□11T3...

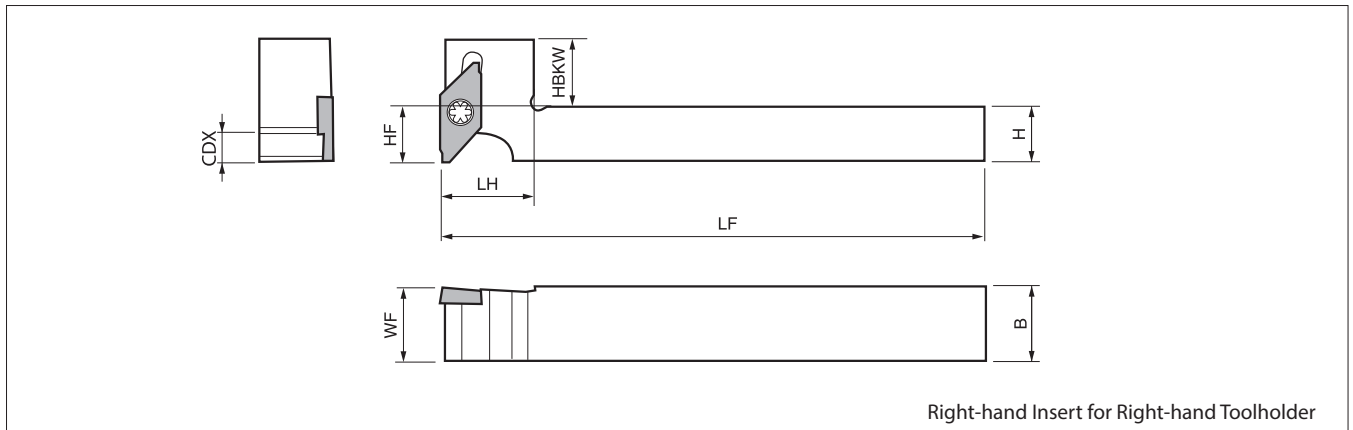

Toolholder Dimensions

Description	Stock		Dimensions(mm)								Spare Parts		Applicable Insert
	R	L	H	HF	B	LF	LH	WF	CDX	HBKW	Clamp Screw	Wrench	
KTKFR 1216JX-12-Y	●		12	12	16	120	20	16	6	15	SB-4590TRWN	FT-10	TKF12R...
1616JX-12-Y	●		16	16	16		25	16		11			

CDX shows the distance from the toolholder to the cutting edge.

● : Standard Stock

External Turning

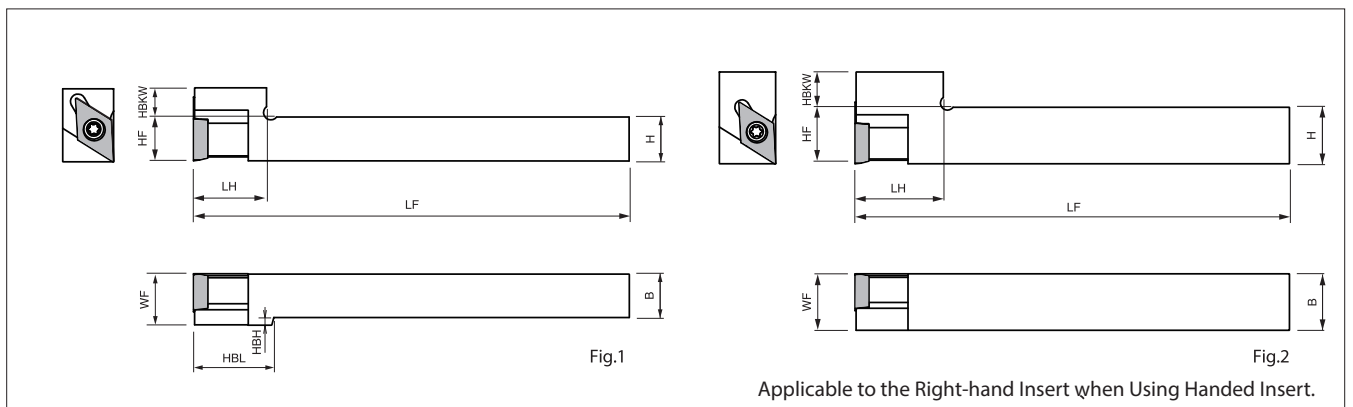

Toolholder Dimensions

Description	Stock		Dimensions(mm)									Shape	Spare Parts		Applicable Insert
	R	L	H	HF	B	LF	LH	WF	HBKW	HBL	HBH		Clamp Screw	Wrench	
SDJCR 1212JX-11FF-Y	●		12	12	12	120	20	14	8	22	2	Fig.1	SB-4085TR	FT-15	DC□□ 11T3...
1616JX-11FF-Y	●		16	16	16		25	16	10	-	-	Fig.2			

● : Standard Stock

Please check precautions for use on back cover.

Precautions

Do not use Y-axis toolholders side by side to prevent interference. (Only two Y-axis holder can be used at the same time)

With interference

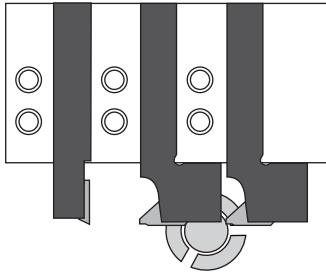

Without interference

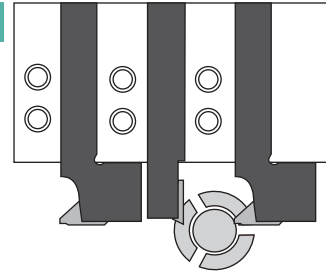

Standard toolholders may be mounted between two Y-axis toolholders.

When changing the tool, set the retracted position with reference to the cutting edge of the Y-axis holder. (When exchanging from tool B to D)

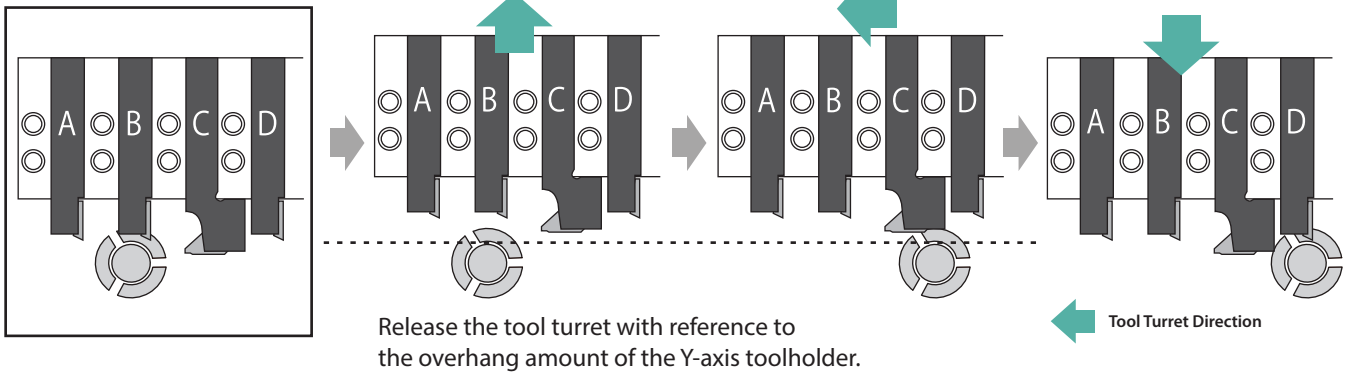

Note that using other toolholders together will result in different outside diameters.

(Unit : mm)

Y-axis Toolholder Overhang	Examples	Overhang Amount : L			
		Available Outside Cutting Diameter (ø)	20	22	25
20		A	Without Restriction	Without Restriction	Without Restriction
		B	13.0	13.0	13.0
		C	Without Restriction	Without Restriction	Without Restriction
25		A	38.0	58.0	Without Restriction
		B	14.9	13.6	13.0
		C	45.0	60.0	Without Restriction